

UM6BG1TCX

ISUZU

ISUZU MOTORS ENGINE SALES INC.

UM6BG1TCX

DIMENSIONS (mm)

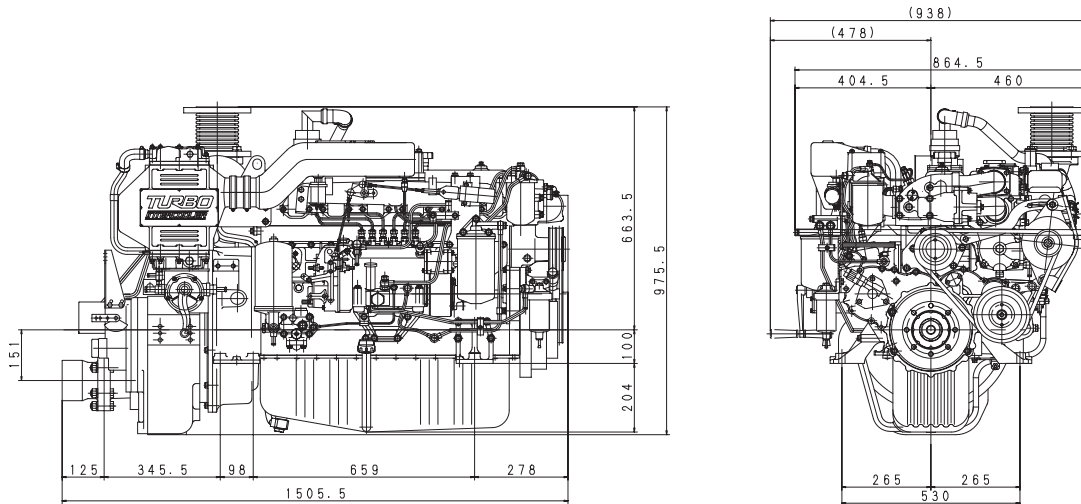

PERFORMANCE CURVES

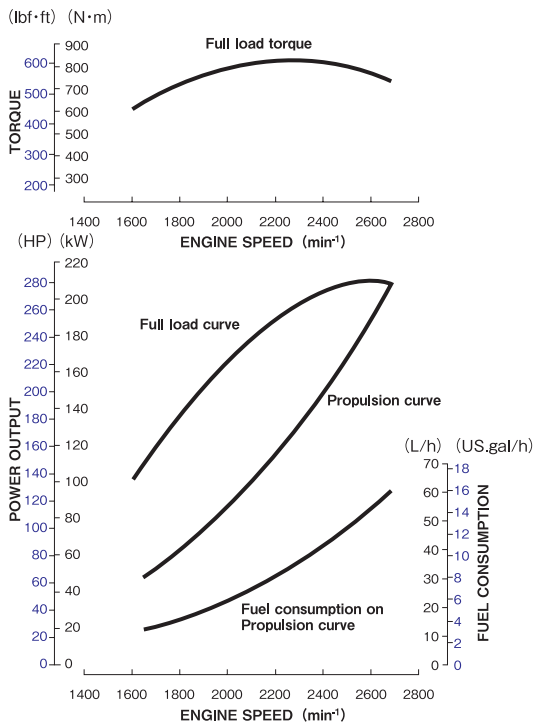

ENGINE SPECIFICATIONS

Configuration	6-cylinder, vertical in-line, 4-cycle deisel engine	
Bore x Stroke	mm (in)	105x125(4.13x4.92)
Displacement	Lit. (cid)	6.494 (396)
Rated output	kW(PS)/min ⁻¹	Medium duty
		Light duty
		191 (260)/2600
		210 (285)/2700
Application	Commercial use	
Governor type	Mechanical	
Combustion type	Direct injection	
Aspiration	Turbo charged / Intercooler	
Exhaust gas status	IMO Tier II	
Engine weight	kg (lb)	Engine
		with MGN40E-1A
		645 (1,422)
		820 (1,808)
Fuel used	Diesel fuel	
Starter	V-KW	24 - 4.5
Alternator	V-A	24 - 40
Lubrication method	Full flow pressure circulation	
Cooling method	Freshwater, full flow pressure circulation (Seawater, indirect)	
Heat exchanger (seawater circulation)	Multi-tube type (freshwater→seawater)	
Intercooler	Multi-tube type (seawater circulation)	
Rotation direction	Crankshaft	Right (clockwise) viewed from front of engine
	Propeller shaft	Right (clockwise) viewed from stern
Idling speed	min ⁻¹	550
Marine gear	Marine Gear Model	MGN40E-1A
	Clutch type	Wet, Multi-plate hydraulic type
	Reverse type	Constant-mesh type gear
	Reduction ratio	2.33, 2.91, 3.45

Specifications subject to change without notice

ACCESSORIES

Standard

- Installation kit
- Battery relay
- Extension harness (5m)
- Seawater pump impeller *
- Bilge pump
- Control head
- Instrument panel
- Oil drain pump
- Blow-by pipe
- V-belt *
- Tool kit
- Owner's manual

* spare parts

Option

- Extension harness (5m)
- Control cable (4m,6m,10m,12m)
- Stop cable (4m,6m,8m)
- Kingston valve

ISUZU MOTORS ENGINE SALES INC.

<http://www.ies.isuzu.co.jp>

